

Roller Blinds • Rollo • Rouleaux

Model • Typen • Modèles RL01, RL06, RL07

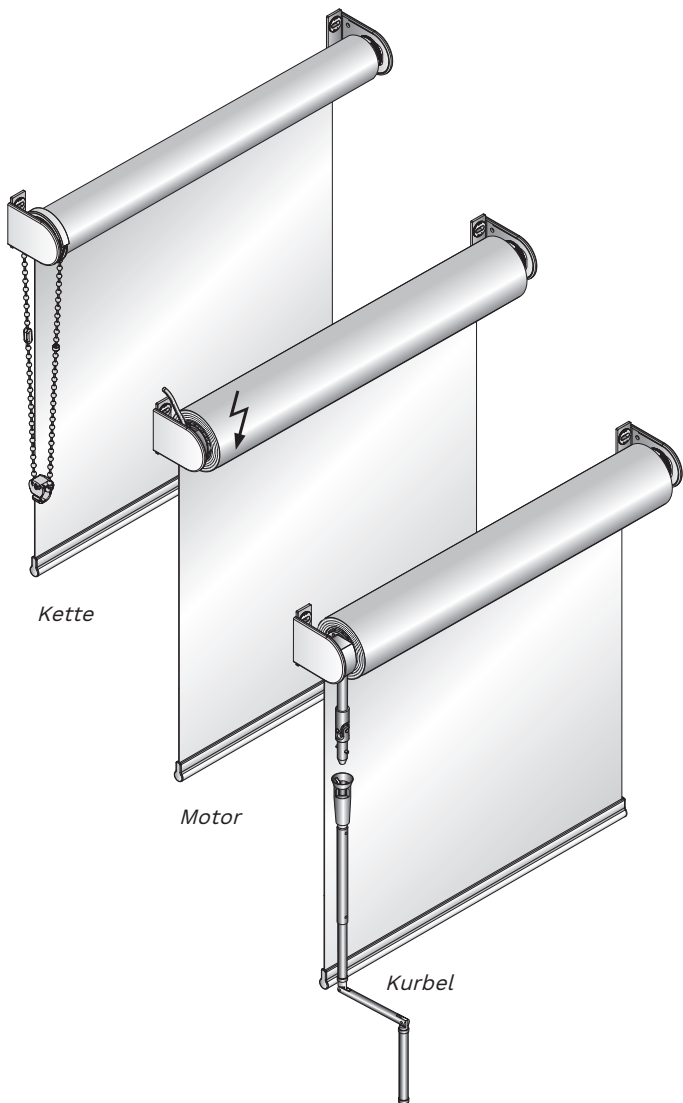

DE Druckfehler, Irrtümer und Änderungen vorbehalten

EN Misprints, errors and changes excepted

FR Sous réserve de fautes d'impression, d'erreurs et de modifications



DE

Verehrte Kundin, verehrter Kunde,

dieses maßgerechte Produkt wurde speziell für Ihre Bedürfnisse hergestellt. Hochwertige Materialien und ein formvollendetes Design gewährleisten eine lange Lebensdauer und bieten somit viel Freude an dem erworbenen Produkt.

Ihr Sonnenschutz Hersteller



Bitte lesen Sie die nachfolgenden Hinweise sorgfältig vor der Montage



Fachkundige Montage erforderlich.
Unsachgemäße Montage kann zu Unfällen führen.
Ausführungsänderungen nur nach Absprache mit dem Hersteller.

Montageschrauben zur Befestigung sind nicht beigelegt.
Achten Sie bitte darauf, dass Sie Schrauben entsprechend der Fensterbeschaffenheit und mit ausreichender Haltekraft verwenden!



WARNUNG



Siehe Seite 15!



EN

Dear Customer,

this dimensionally accurate blind was produced especially according to your requirements. High quality materials and a design that is perfect in function and elegance guarantee a long service lifetime and thus ensure great pleasure in the purchased product.

Your blind Manufacturer



Please read this instructions carefully before fitting the blind



Blinds must be fitted by skilled personnel.
Wrong installation may result in accidents.
Alterations of the blind must be approved by the blind manufacturer.

No screws for fixing are enclosed. Always use appropriate screws and plugs suited for the wall or ceiling material where the blind is fitted!



WARNING



See page 15!



FR

Chers clients,

Ce store sur mesure a été conçu pour s'adapter parfaitement à vos fenêtres. Les matériaux de haute qualité utilisés et son design lui garantissent une élégance et une fonctionnalité d'une excellente longévité, pour vous offrir entière satisfaction.

Votre fabricant store



Veillez lire attentivement les instructions avant de procéder au montage.



Les stores doivent être posés par des personnes qualifiées.
Le non respect de cette préconisation peut provoquer des accidents.
L'acheteur ou un tiers ne doivent pas modifier ou altérer le produit.

La visserie des supports n'est pas fournie. C'est pourquoi il est nécessaire de choisir des vis et des prises de courant suffisamment résistantes qui s'adaptent au matériau de la fenêtre.



MISE EN GARDE



Regardez à la page 15!



Montage • Installation • Pose

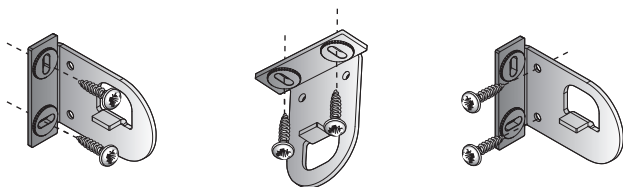

Kette
Motor B

Motor A

Kurbel

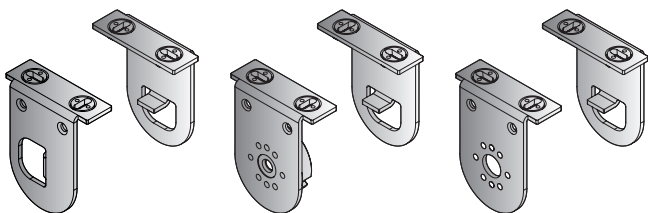

Motor A: Somfy LT 50 Start / Somfy RTS 50 Sonesse

Motor B: Somfy Sonesse 40 / Somfy Sonesse 40 RTS

1

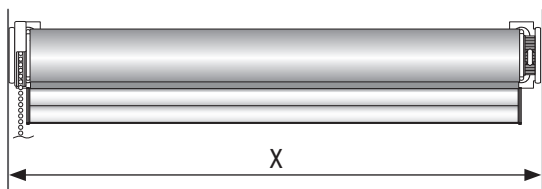

2

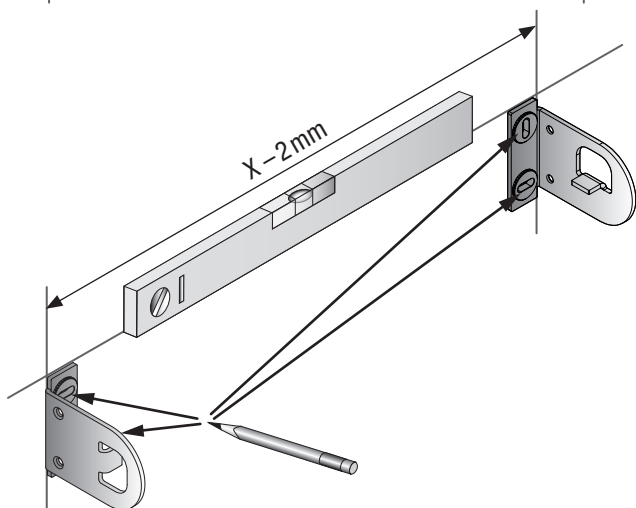

3

3

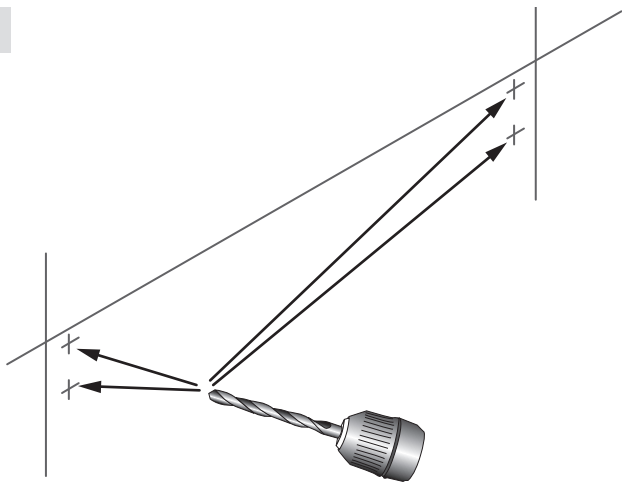

4

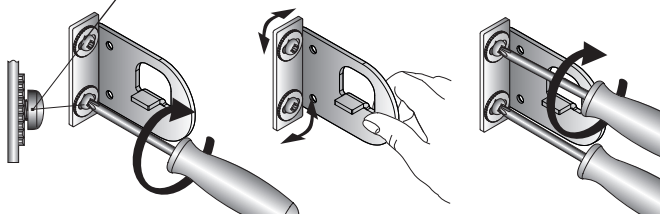
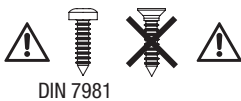
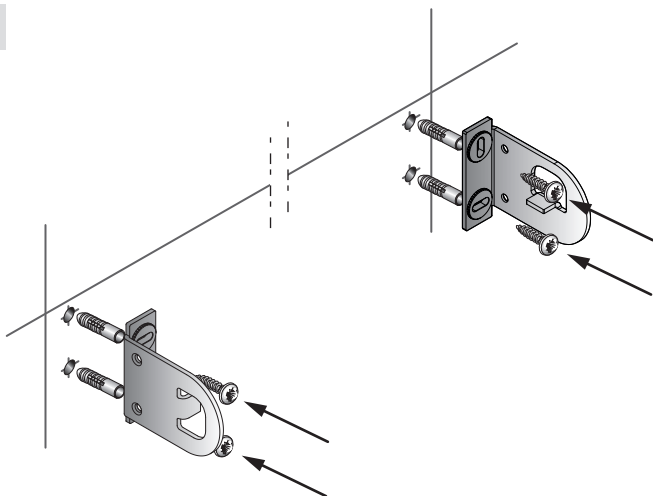

5

Kette

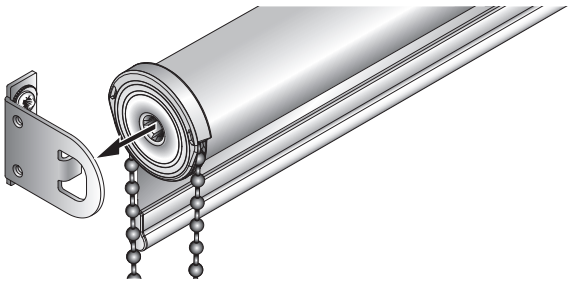

Motor B

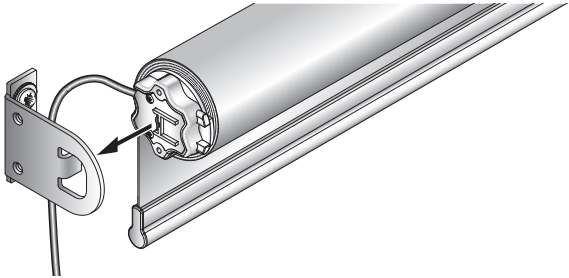

Motor A

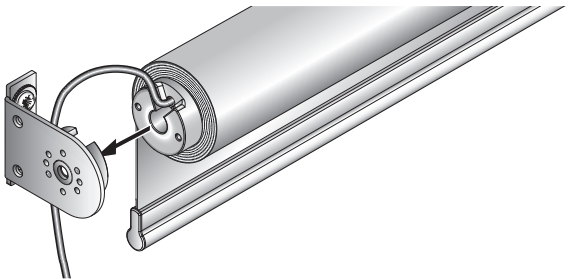

Kurbel

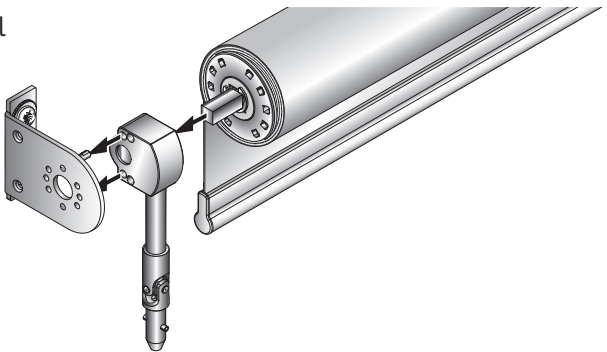

Montage • Installation • Pose

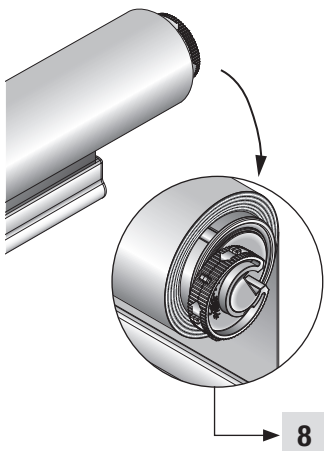
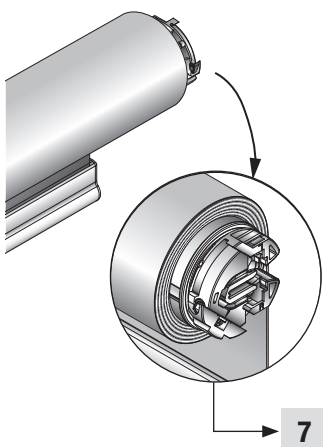

7a

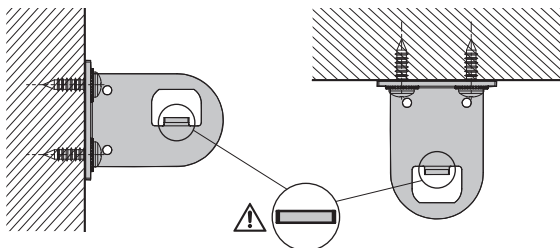
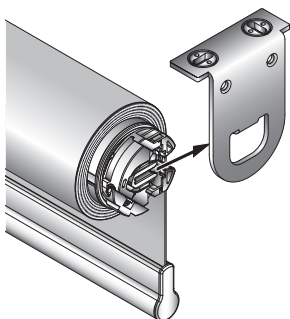
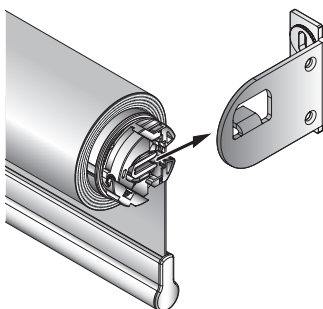

Montage • Installation • Pose

7b

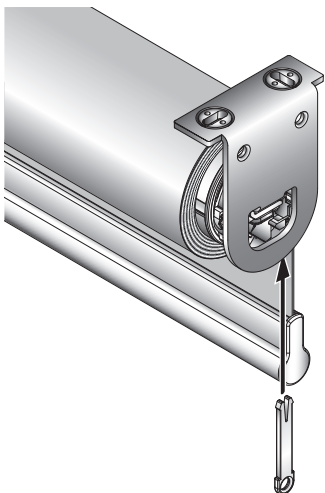

7c

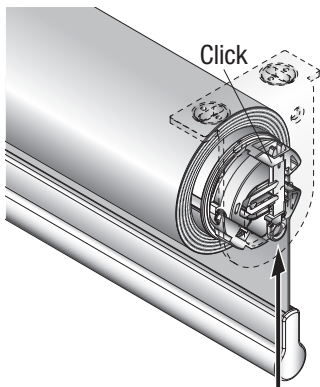

7d

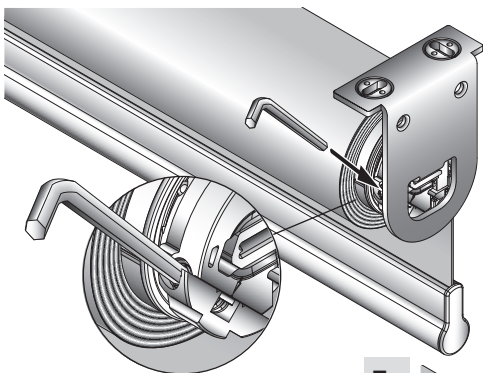

7e

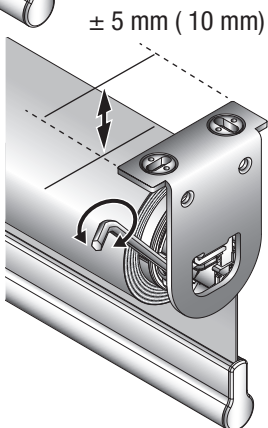

8a

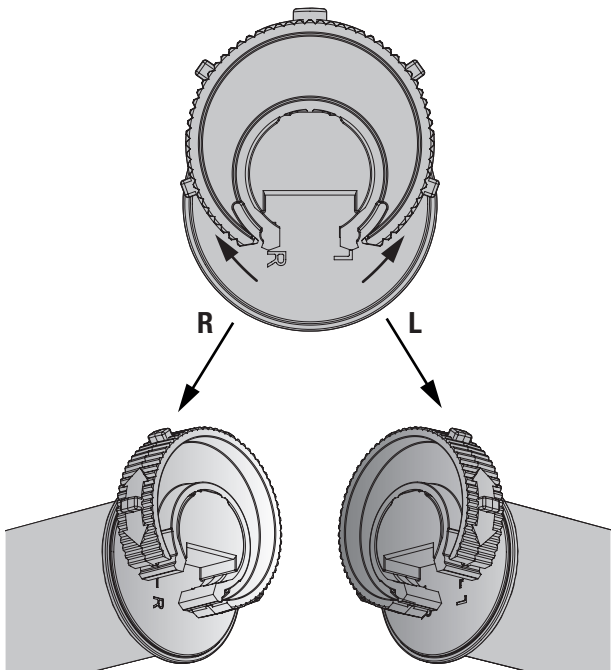
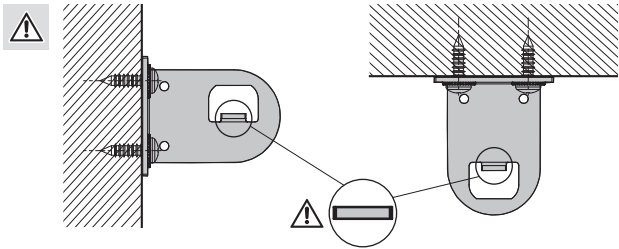

8b

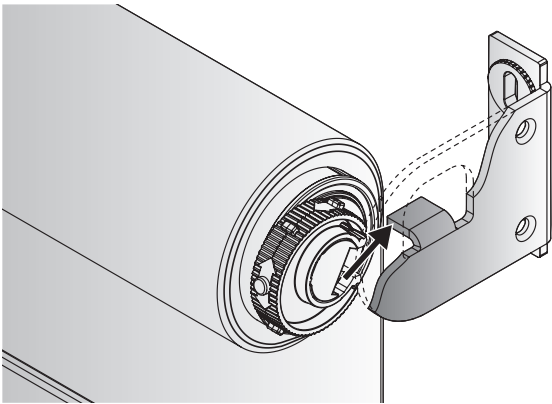

8c

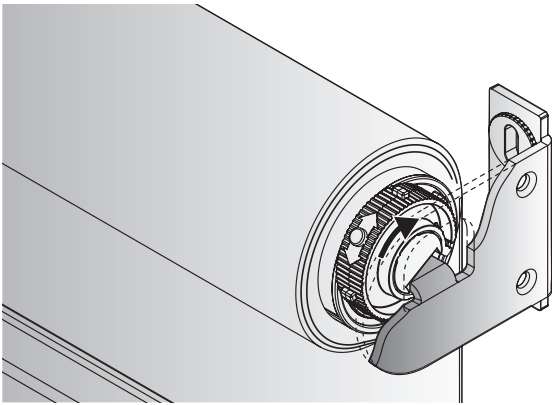

8d

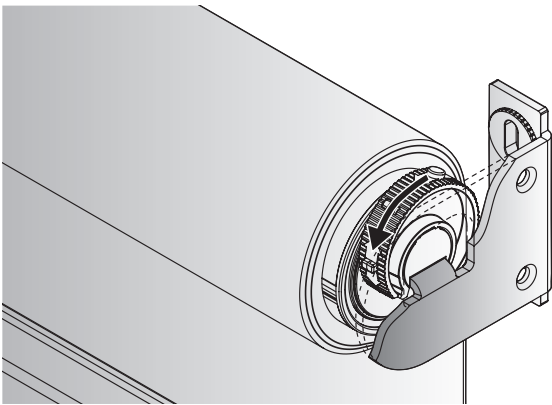

8e

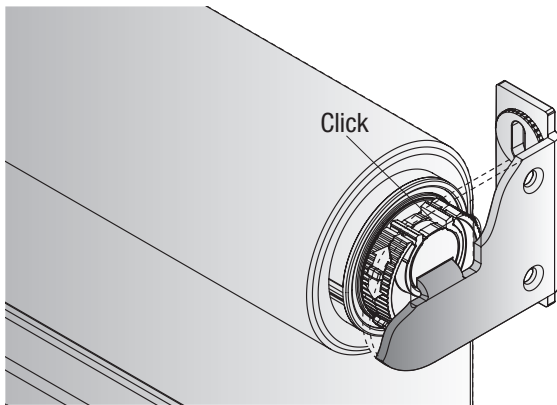

9



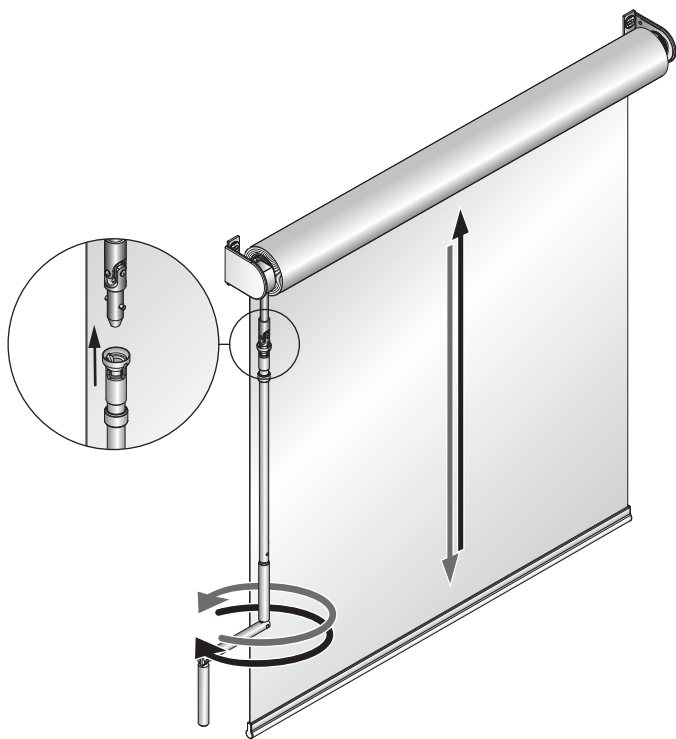
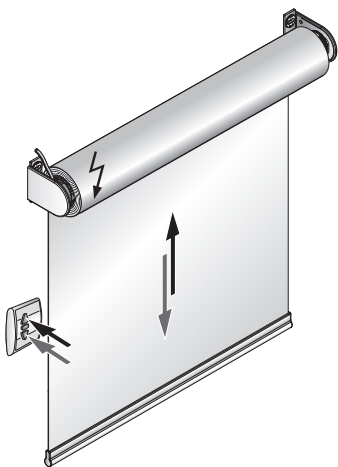
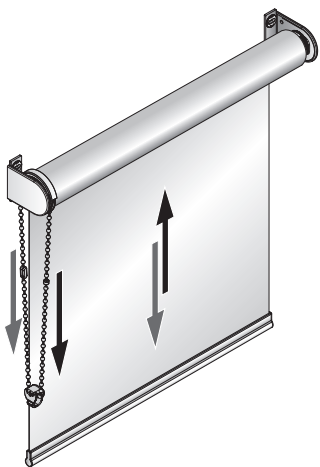

Demontage • Disassembly • Démontage

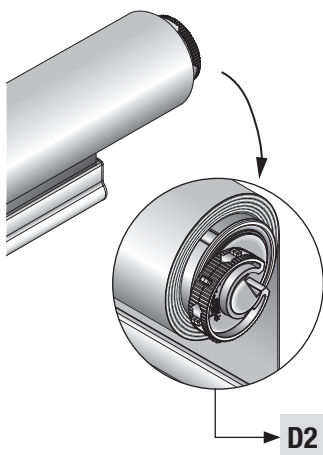
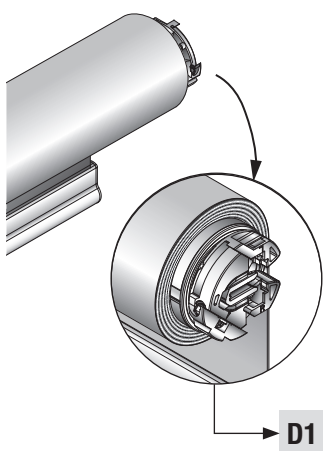

D1

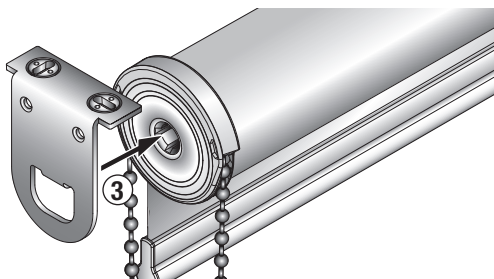
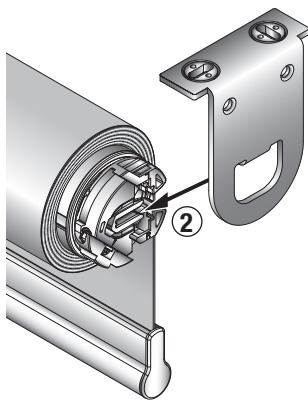
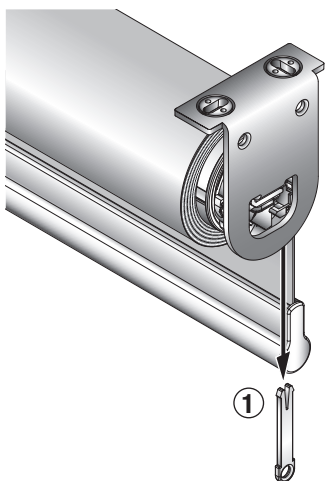

D2

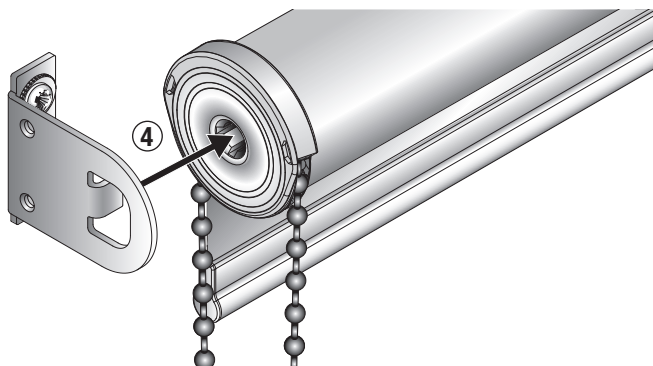
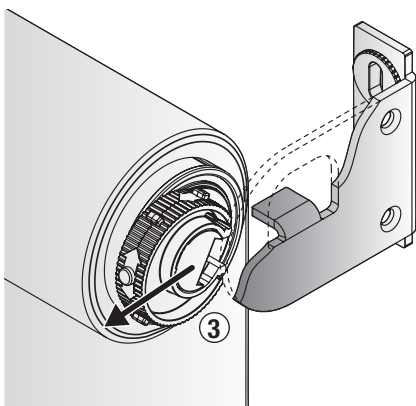
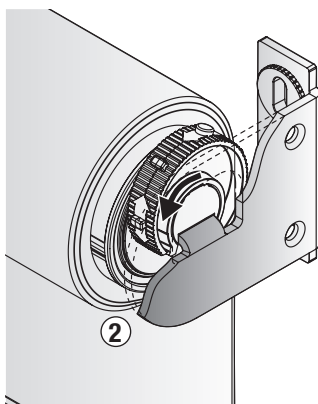
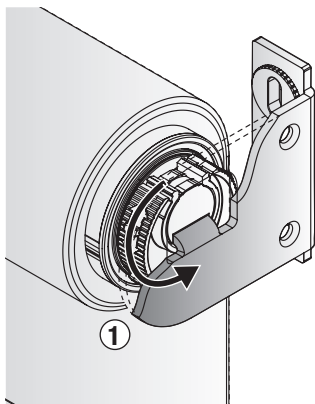

DE



WARNING



- Kleinkinder können sich unter Umständen in den Schlaufen von Schnüren, Ketten und Bändern zur Bedienung der Fensterverkleidung verfangen und erwürgen. Es besteht die Gefahr, dass sie sich Schnüre um den Hals wickeln.
- Um dies zu verhindern, sind die Schnüre aus der Reichweite von Kleinkindern zu halten.
- Kinderbetten und Einrichtungsgegenstände sollten sich nicht in der Nähe der Bedienschnüre befinden.
- Schnüre nicht zusammenbinden.



- Darauf achten, dass Schnüre nicht verdrehen und eine Schlaufe bilden.
- Um das Risiko derartiger Unfälle zu verringern, bitte die mitgelieferten Sicherheitsvorrichtungen gemäß der Montageanleitung installieren und verwenden.

gemäß Norm EN 13120

EN



WARNING



- Young children can strangle in the loop of pull cords, tapes and cords that operate window coverings. They can also wrap cords around their necks.
- To avoid strangulation and entanglement, keep cords out of reach of young children.
- Move beds, cots and furniture away from window covering cords.
- Do not tie cords together. Make sure cords do not twist and create a loop.
- Install and use the included safety devices according to the installation instructions on these device to reduce possibility of such an accident.



According to EN 13120

FR



MISE EN GARDE



- Les jeunes enfants peuvent s'étrangler ou s'emmêler avec les cordons de levage, la chaînette, et les cordes qui actionnent les stores. Ils peuvent également enrouler les cordons autour de leur cou.
- Pour leur éviter de s'étrangler ou de s'emmêler dans les cordons, maintenez ces derniers hors de portée des jeunes enfants.
- Placez les lits, berceaux et mobilier à l'écart des cordons, corde ou chaînette de store.
- Ne nouez pas les cordons ensemble. Veillez à ce qu'ils ne s'enroulent pas en formant une boucle.
- Installez et utilisez les dispositifs de sécurité inclus conformément aux instructions d'installation indiquées sur ces dispositifs pour réduire le risque d'un tel accident.



Conformément à la norme EN 13120

Typ 100

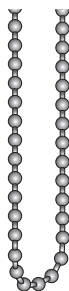
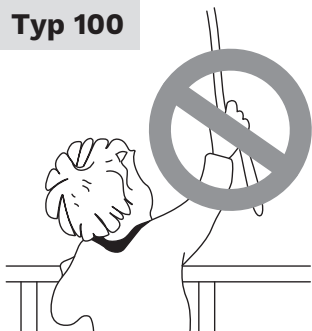

A

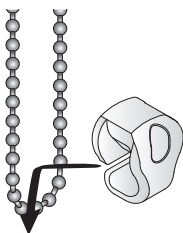

B

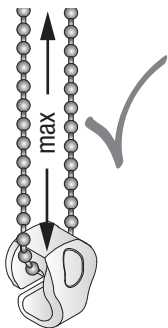

C

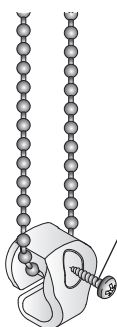

DIN 7981

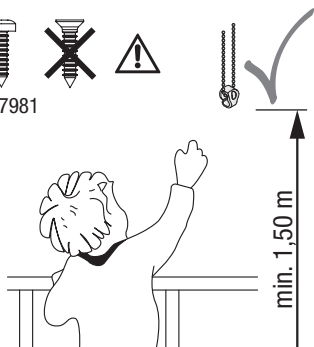

min. 1,50 m